





# Vlaamse Tinvereniging

Het atelier van de Luikse Meester - Tingieters

## Nicolas Dechamps

Jean-Pierre De Graef

---

Gent - Oostakker 16 november 1997

In de catalogus " Etains anciens Huy - Liège du XVIIème au  
XIXème siècle ", vermeldt Maurice Lorenzi drie opeenvolgende  
generaties werkzaam onder de naam Nicolas DECHAMPS :

- Nicolas Dechamps I

( werkzaam vóór 1758 )

- Nicolas Dechamps II

( verwierf het meesterschap in 1762 )

- Nicolas Dechamps III

( werkzaam vanaf 1818 )

## MEESTERMERKEN

### Merk 1: Nicolas Dechamps I



Cirkelvormig merk, met centraal de Aartsengel Michaël staande tussen lauwerkransen, in de linkerhand een balans en in de rechterhand een geheven zwaard, bovenaan en onderaan een banderol met respectievelijk daarin de inscriptie N. DECHAMPS en A. LIEGE.

### Merk 2: Nicolas Dechamps II



Cirkelvormig merk, centraal de afbeelding van een fregat met drie masten met opgerolde zeilen tussen de kapitalen N en D, langs de onderrand gescheiden het jaartal 17 - 62.

### Merk 3: Nicolas Dechamps III

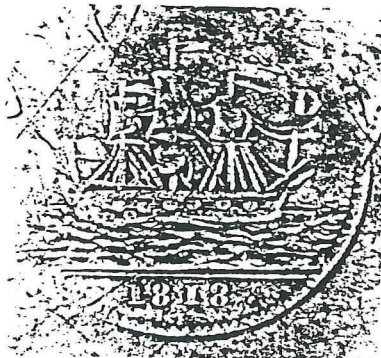

Cirkelvormig merk, centraal de afbeelding van een fregat met drie masten met gespannen zeilen tussen de kapitalen N en D.

Onderaan onder een dubbele lijn het jaartal 1818



## ROOSMERKEN ( kwaliteitsmerken )

Merk 4: Gekroonde roos H 2,5 cm.

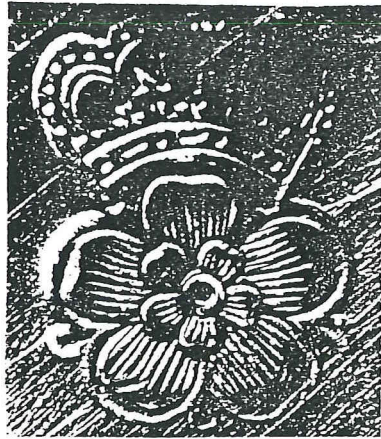

Dubbele krans van vijf rozenbladeren met een parel in het hart.

Kroonband met parels en streepjes.

Kroon met vier bogen versierd met parels en drielobbige bladeren met daarin centraal de kapitalen N en D

Merk 5: Gekroonde roos H. 1,7 cm.



- 5 a. Dubbele krans van vijf rozenbladeren met een parel in het hart, vier van de grote rozenbladeren dragen een parel, het bovenste blad draagt een zesvormige ster. Kroon met twee bogen en de kapitalen N en D. Kroonband met parels, onder de kroonband links en rechts een parel.



- 5 b. De parel rechts onder de kroonband staat op de lijn van de onderste rand.

Merk 6 Gekroonde roos - 1,1 cm.

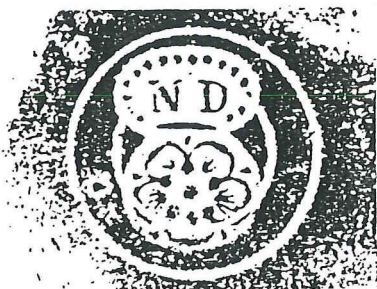

Enkele krans van vijf rozenbladeren met een parel in het hart.

Krooncirkel gevormd door een boog van parels met in het midden de kapitalen N en D

Andere merken

Merk 7.

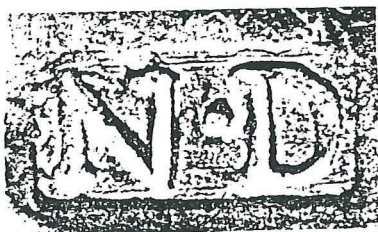

Rechthoekig merk 0,8 / 0,4 cm.

met de initialen N D, voor het merken van maatkannen in de 19e. eeuw.

Merk 8.



Rechthoekig merk met de afkorting E.Fres

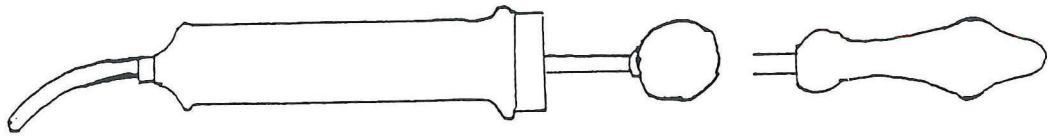

Spuut

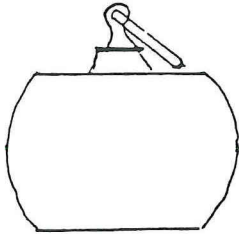

Bedkruik

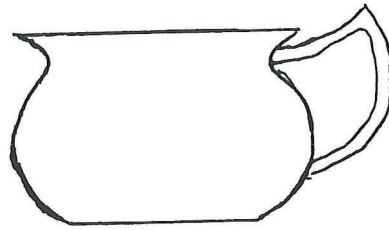

Kamerpot

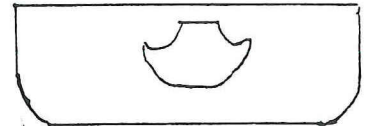

Kom

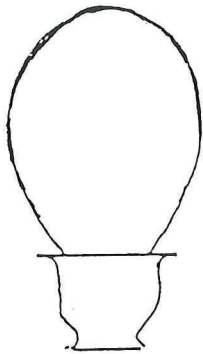

Wijwatervaatje

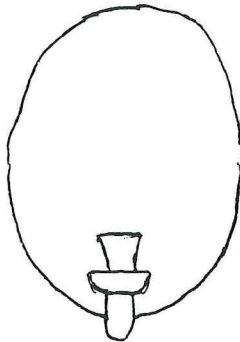

Muurkandelaar

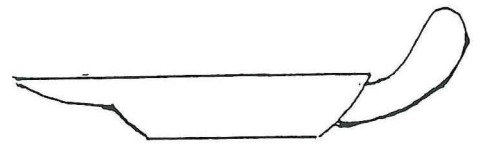

Bloedvanger

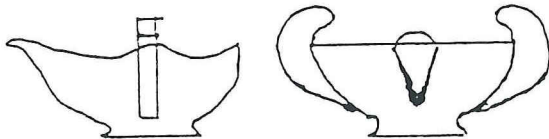

Sauskom

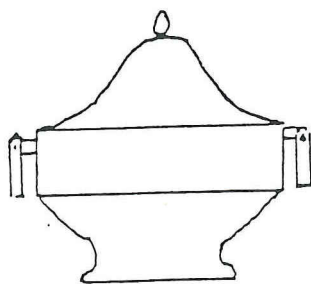

A

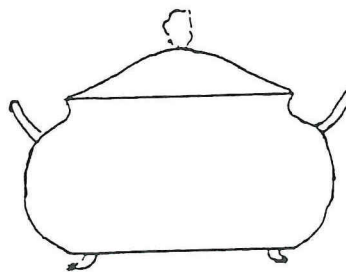

B

Soepterrine

met loshangende  
oren

met vaste oren

ROMFEN

koffiekannen

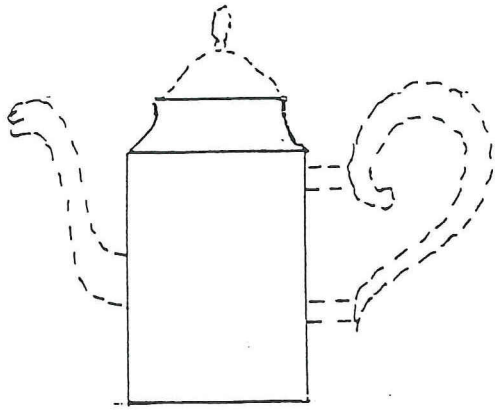

C

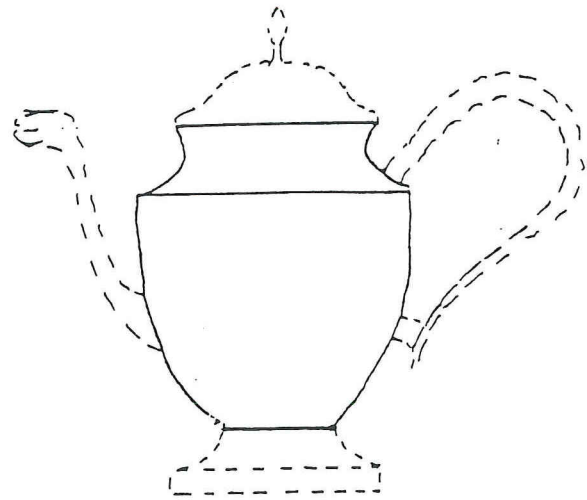

D

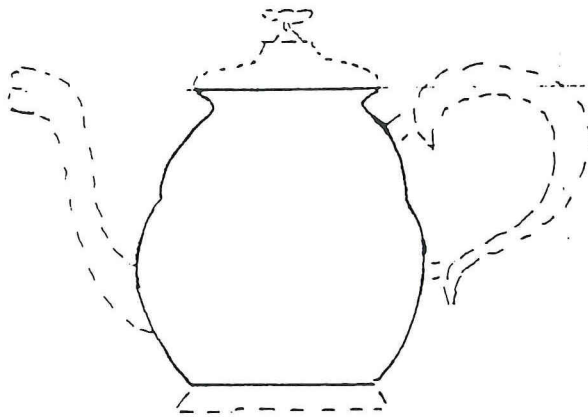

E

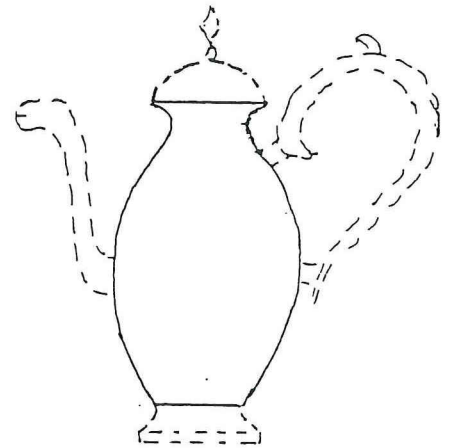

M

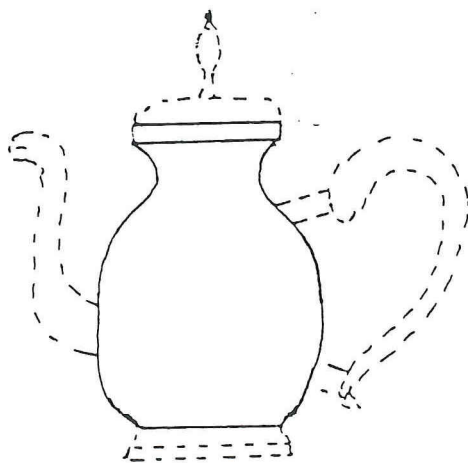

K

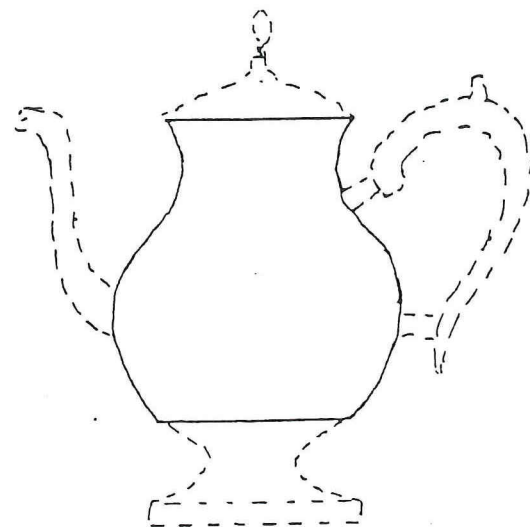

L

ROMPEN

koffiekan  
kan

kan

kan

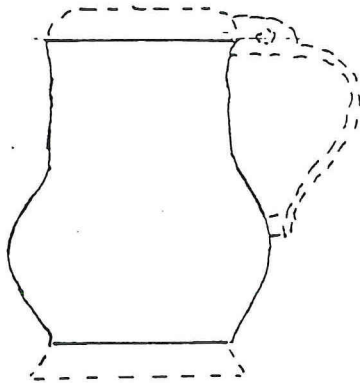

I

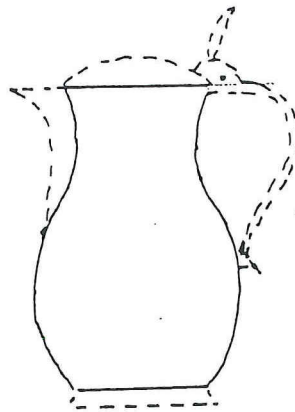

H

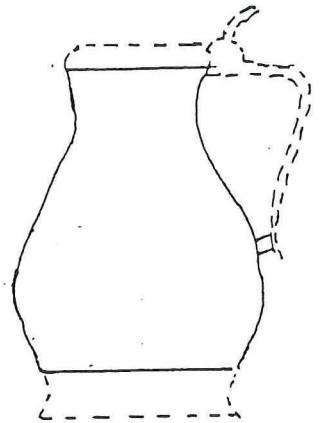

J

melkpot

theepot

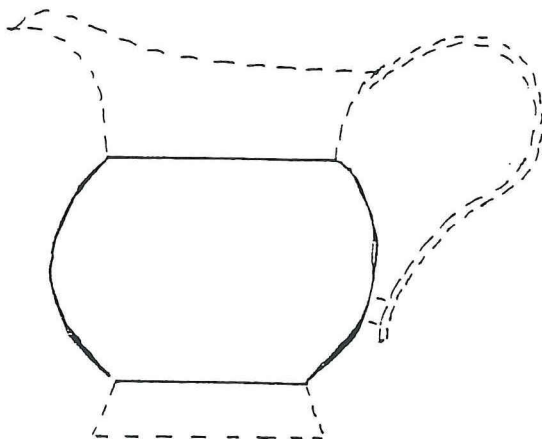

G

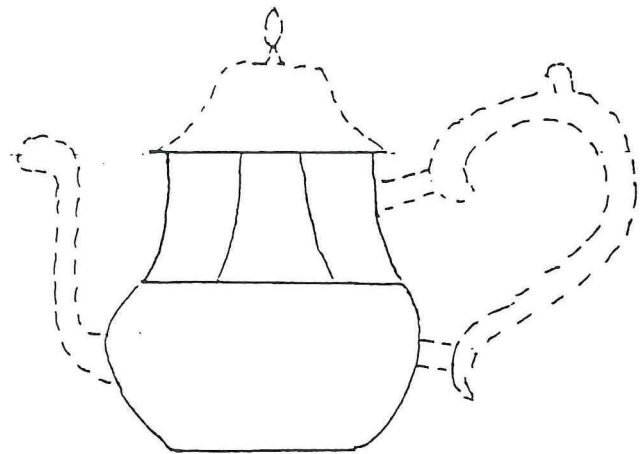

E

metrisch maat

kruik

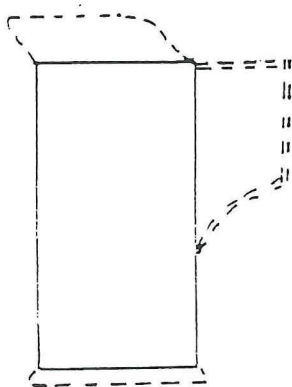

A

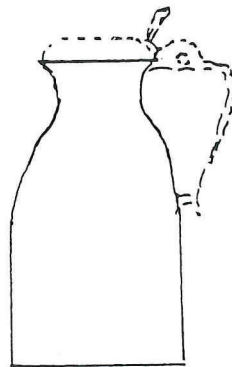

B



DEKSELS

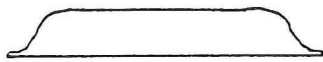

A



B



C

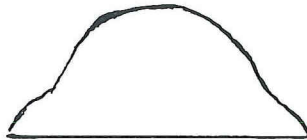

D



E

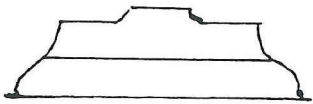

F

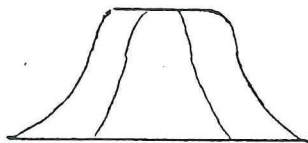

G

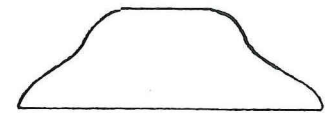

H

VOETEN

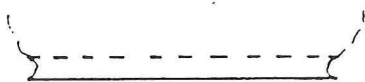

A

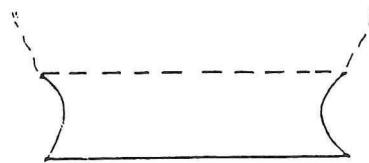

B

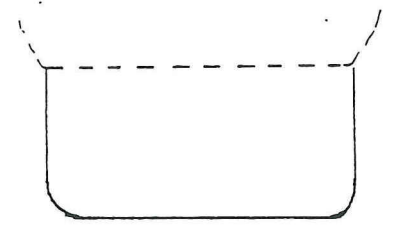

C

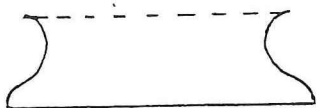

D

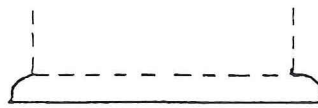

E

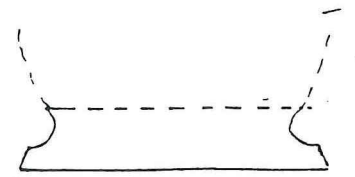

F

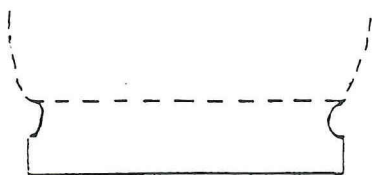

G

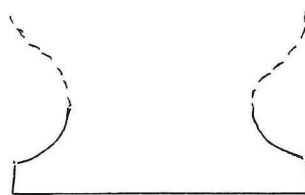

H

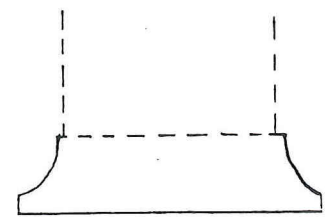

I



J

DEKSELBEKRONING

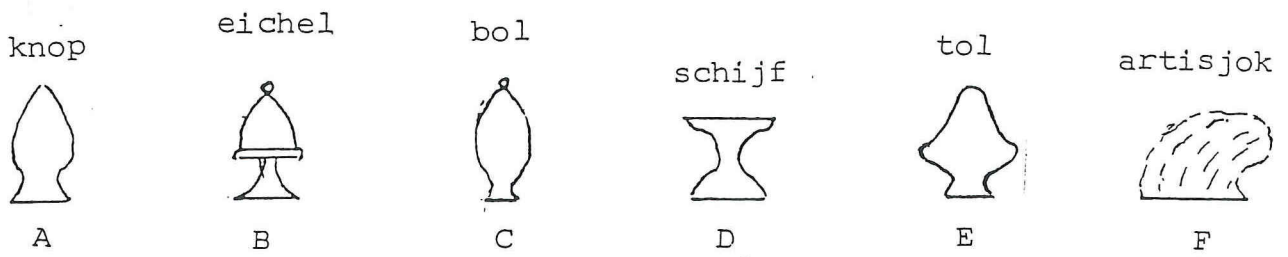

DEKSELGREEP

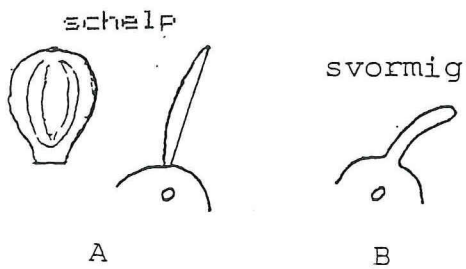

DUIMRUST

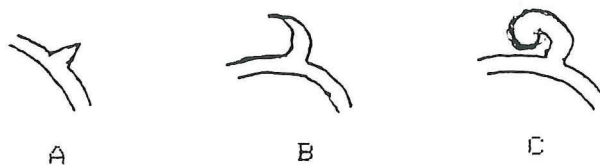

OOR

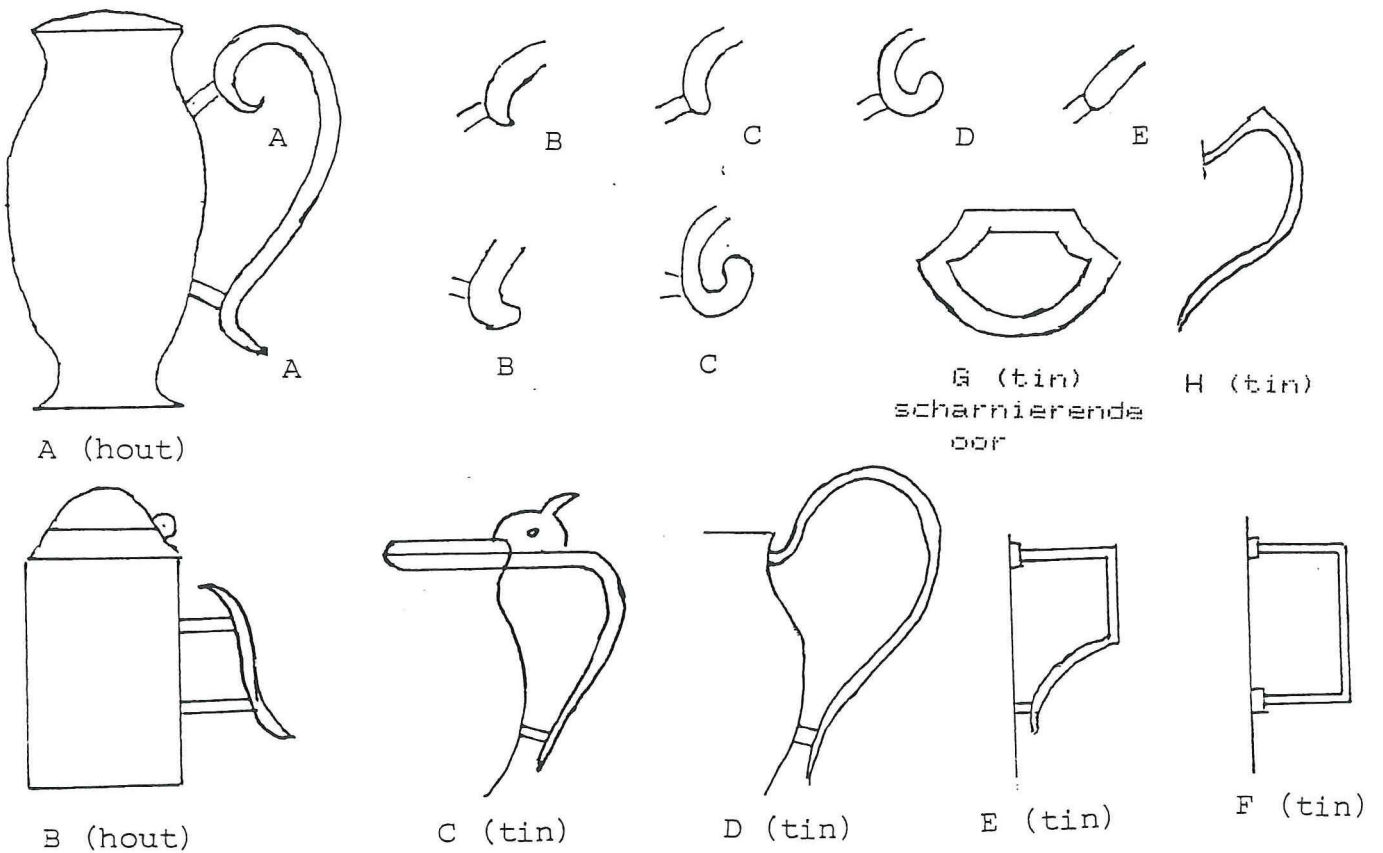

GIETMIDDEL

